

(No Model.)

2 Sheets—Sheet 1.

J. M. KLEIN.
LATHE CARRIER.

No. 407,666.

Patented July 23, 1889.

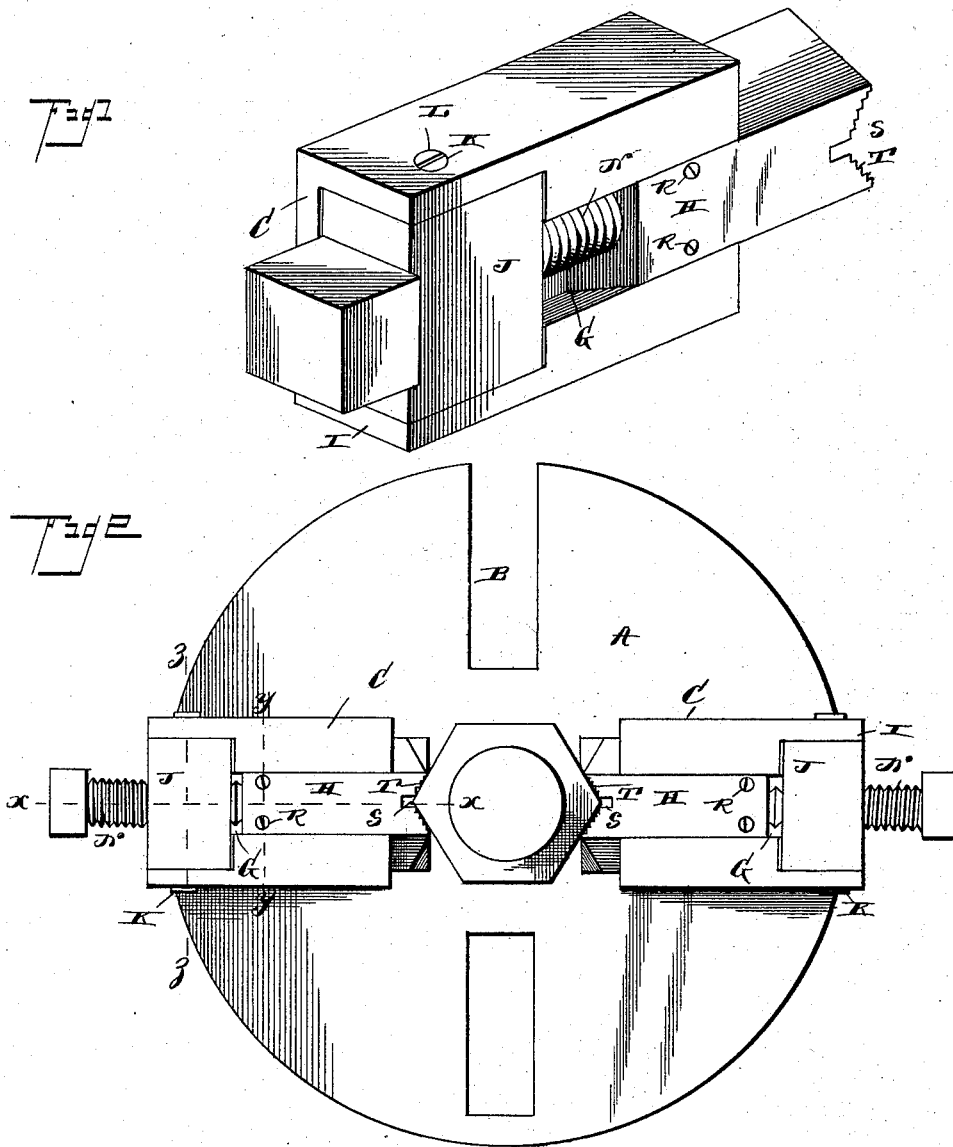

Witnesses
John Amirie

Wm. Bagger

Inventor

John M. Klein

By his Attorneys

C. A. Snow & Co

(No Model.)

2 Sheets—Sheet 2.

J. M. KLEIN.
LATHE CARRIER.

No. 407,666.

Patented July 23, 1889.

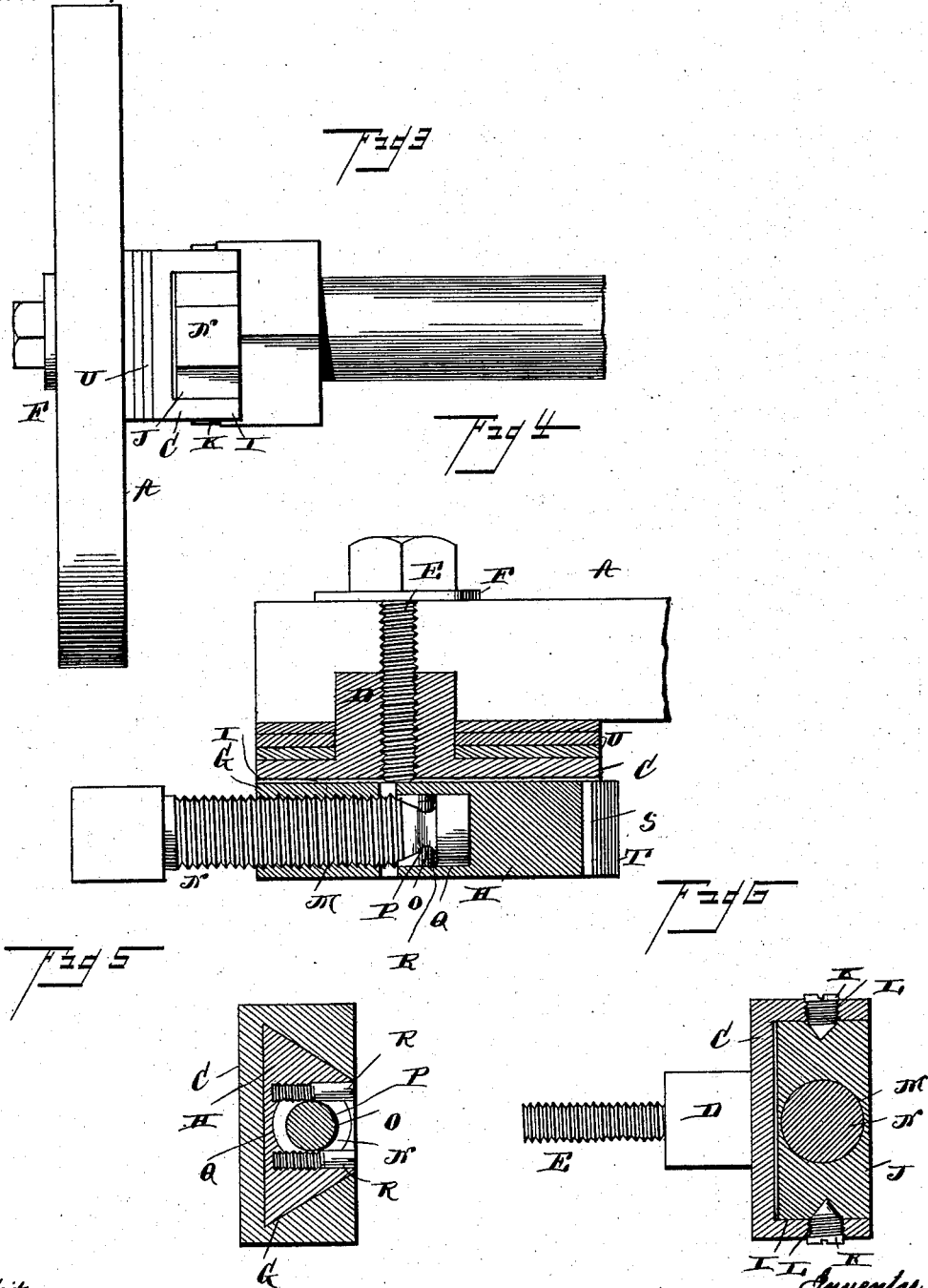

Witnesses
John Amiee
Wm. Bagger

Inventor
John M. Klein

By his Attorneys
Ch. Snow & Co.

UNITED STATES PATENT OFFICE.

JOHN M. KLEIN, OF ALTOONA, PENNSYLVANIA.

LATHE-CARRIER.

SPECIFICATION forming part of Letters Patent No. 407,666, dated July 23, 1889.

Application filed March 20, 1889. Serial No. 303,976. (No model.)

To all whom it may concern:

Be it known that I, JOHN M. KLEIN, a citizen of the United States, residing at Altoona, in the county of Blair and State of Pennsylvania, have invented new and useful Improvements in Lathe-Carriers, of which the following is a specification.

This invention relates to that class of devices which are known as "lathe-carriers" for bolt-turning lathes; and it has for its object to provide a device of this class which shall be simple in construction, easily attached to and adjusted upon the face-plate of a lathe, and which may be conveniently adjusted and operated, so as to grasp and hold the heads of bolts of various sizes while being operated upon.

The invention consists in the improved construction and arrangement of its component parts, which will be hereinafter fully described, and particularly pointed out in the claims.

In the drawings, Figure 1 is a perspective view of my improved lathe-carrier detached. Fig. 2 is a front view of the face-plate of a bolt-turning lathe equipped with my improved carriers. Fig. 3 is a side view of the same. Fig. 4 is a sectional view taken on the line xx in Fig. 2. Fig. 5 is a sectional view taken on the line yy in Fig. 3. Fig. 6 is a sectional view taken on the line zz in Fig. 2.

The same letters refer to the same parts in all the figures.

A designates the face-plate of an ordinary bolt-turning lathe, which is provided with the radial slots B B, in which the carriers are to be adjusted.

My improved lathe-carriers consist each of a block or box C, having on its under or inner side the rectangular stud D to enter the slot B in the face-plate, in which it is secured by means of a bolt E entering the said stud from the opposite side of the face-plate, a washer F being interposed between the face-plate and the bolt-head.

The front side of the box C has a recess G, the outer portion of the walls of which is straight, while the inner portion of said walls is dovetailed to retain in position a correspondingly-shaped slide H. In the outer end of the recess G, between the straight portion of the walls I of said recess, is arranged a

block J, which, in order to enable it to adapt itself to various adjustments of the bolt working therein, is mounted so as to have a slight rocking or oscillating motion upon the trunnions or screw-studs K, Fig. 6, entering the sides of said block J through perforations L in the sides of the walls I. The block J has a longitudinal screw-threaded opening M, in which works a screw-threaded bolt N, the inner end of which has a reduced cylindrical portion O, provided with an annular groove P. The adjacent end of the dovetailed slide H is provided with a cylindrical recess Q, adapted to receive the cylindrical portion O of bolt N, which is retained in the said recess by means of pins or screws R, extending through the slide H. By this construction it will be seen that by operating the bolt N the slide H may be caused to move longitudinally in either direction in the recess G of the block or box C.

The inner end of the slide H is provided with an angular recess S, the walls of which are toothed or serrated, as shown at T, in order that the said slide may have a firm bite or hold upon the head of the bolt when the latter shall be adjusted for operation. When the lathe-carriers are attached to the face-plate of the lathe, washer-plates or liners U may be interposed between the face-plate and the under sides of the carriers for the purpose of raising the latter to any desired distance from the face-plate.

From the foregoing description, taken in connection with the drawings hereto annexed, the operation and advantage of my invention will be readily understood. When lathe-carriers of ordinary construction are used, a separate set of carriers is required for almost every size of bolt that is to be made, as well as for the various sizes of round iron which it may be desired to operate upon. Not only is additional expense thereby incurred, but considerable time is frequently consumed in changing the carriers upon the face-plate. By my invention a single set of carriers may be used to hold bolts or round iron of many different sizes, and a saving in time as well as in material is thus effected. It will also be seen that the slides H of my improved carriers may be raised sufficiently from the face-plate to enable countersink head-bolts to be operated upon, inas-

much as the heads of such bolts will pass under the slides H and not interfere with the operation of the said slides. In the manufacture of this class of bolts the common practice has been to leave a portion of surplus stock projecting from the head to enable the bolt to be grasped by the lathe-carriers while the bolt is being turned. This projecting surplus stock, which required afterward to be removed, goes to waste, while the time required to remove it is also of some consequence.

By the use of my invention a saving of material may be effected in the manufacture of this class of bolts as well as in time.

Having thus described my invention, I claim and desire to secure by Letters Patent—

1. In a lathe-carrier for bolt-turning lathes, the combination, with a block or box mounted adjustably and detachably upon the face-plate of a lathe, of a longitudinally-movable dovetailed slide, the projecting end of which has a toothed angular recess, and in the opposite end of which is swiveled the end of an operating-bolt, substantially as set forth.

2. In a lathe-carrier, the combination, with the block or casing mounted adjustably and detachably upon the face-plate of a lathe, of a longitudinally-movable dovetailed slide, a block or nut secured between the sides of the casing, and a bolt working in the said nut and having its inner end swiveled in a recess in the rear end of the sliding block, substantially as set forth.

3. In a lathe-carrier, the combination of a block or casing, a longitudinally-movable dovetailed slide having an angular toothed recess at its projecting end, a block or nut mounted in the said casing and having a limited

oscillating or rocking motion, and a bolt extending through said nut and having its inner end swiveled in a recess in the dovetailed slide, substantially as set forth.

4. In a lathe-carrier, the combination of a block or casing, a dovetailed slide movable longitudinally therein, a nut arranged between the walls of the casing and mounted upon screw-threaded studs or trunnions, and a bolt working in said nut and having its inner end swiveled in the said slide, substantially as set forth.

5. In a lathe-carrier, the combination, with the block or casing having on its rear side a rectangular stud provided with a screw-threaded recess, of one or more washers or liners and the bolt to secure it to the face-plate of a lathe, substantially as herein described, and for the purpose set forth.

6. As an improvement in lathe-carriers, the combination of a block or casing having on its rear side the rectangular stud provided with a screw-threaded recess, a dovetailed slide movable longitudinally in the said casing and having an angular toothed recess at its projecting end, and a bolt working in a nut which has a limited rocking or oscillating motion between the walls of the casing, the inner end of said bolt being swiveled to the longitudinally-movable slide, substantially as and for the purpose herein set forth.

In testimony that I claim the foregoing as my own I have hereto affixed my signature in presence of two witnesses.

JOHN M. KLEIN.

Witnesses:

S. H. BREMANAN,
JOHN S. WILLIS.